

Danfoss



Installation Manual

Danfoss GX 850 Dual Zone
Automatic Control Panel



CONTENTS - GX 850 Dual Zone ACP

	Page
Description	2
Specifications	2
Schematic Diagram.....	2
Installation Examples	3
Single Zone (less than 50 amps).....	3
Single Zone (greater than 50 amps).....	3
Dual Zone.....	3
Terminal Block.....	4
Installing Ground Sensors	4
Installing an Individual Ground Sensor	5
Installing a Sensor Cable	5
Installing a Ground Sensor and a Conduit	5
Installation in Asphalt	5
Installing Roof Sensors	6
Installing an Individual Roof Sensor	6
Factory Settings	7
Part Numbers	7
Warranty	10



Danfoss GX 850 Dual Zone Automatic Control Panel (ACP)

The GX 850 Dual Zone Automatic Control Panel (ACP) is the most optimal solution for keeping an area free of ice and snow. The GX 850 ACP is like having a mini weather station monitoring your installation 24 hours a day. Collecting temperature and relative humidity information from sensors embedded in the surface material, it is able to accurately sense when to turn the system on and off. The GX 850 ACP perfectly balances the job of clearing snow and ice while minimizing energy consumption. By combining moisture and temperature readings, the system is able to save around 75% energy compared to a system which only measures temperature readings.

The GX 850 ACP has an integral alarm function that monitors the attached sensor and the inbuilt microprocessor. An external alarm may also be connected to the system. Voltage options include 208V-600V. If software modification is required, the GX 850 Dual Zone ACP software can be upgraded by using the RS232 data cable.

Specifications

Voltage:	208-600V
Control Voltage:	120V
Enclosure Type:	NEMA 4X
Mounting:	Wall mounted, indoors
Dimensions (HxWxD):	15.5" x 7.5" x 7.0"
Warranty:	2 years
Max. Load:	50A

Provides a complete, efficient snow melting solution.
Requires ground or gutter sensors.

Schematic Diagram

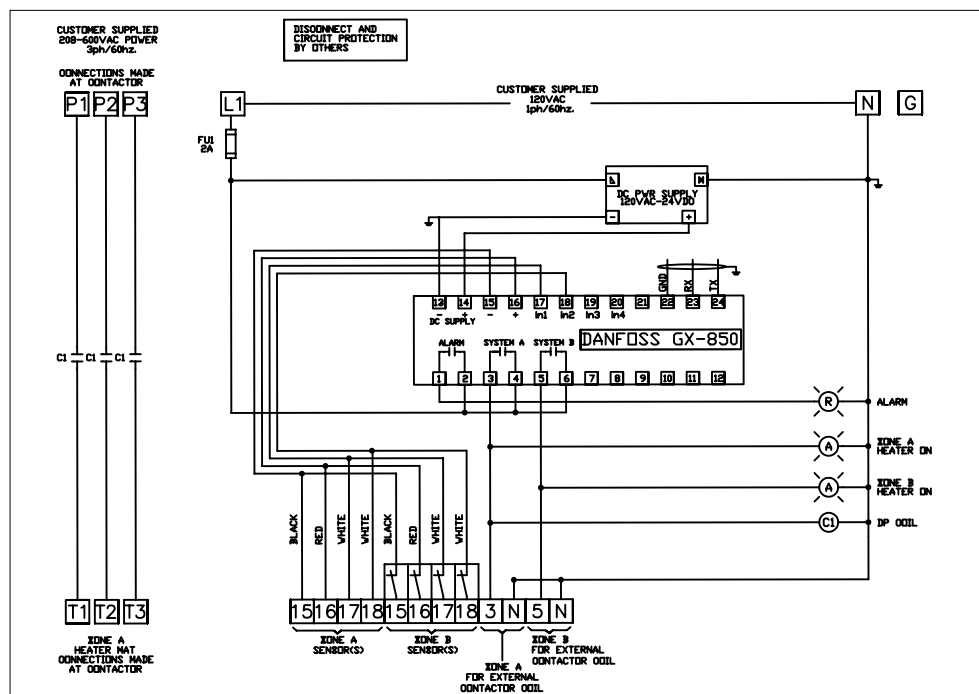

Installation Examples

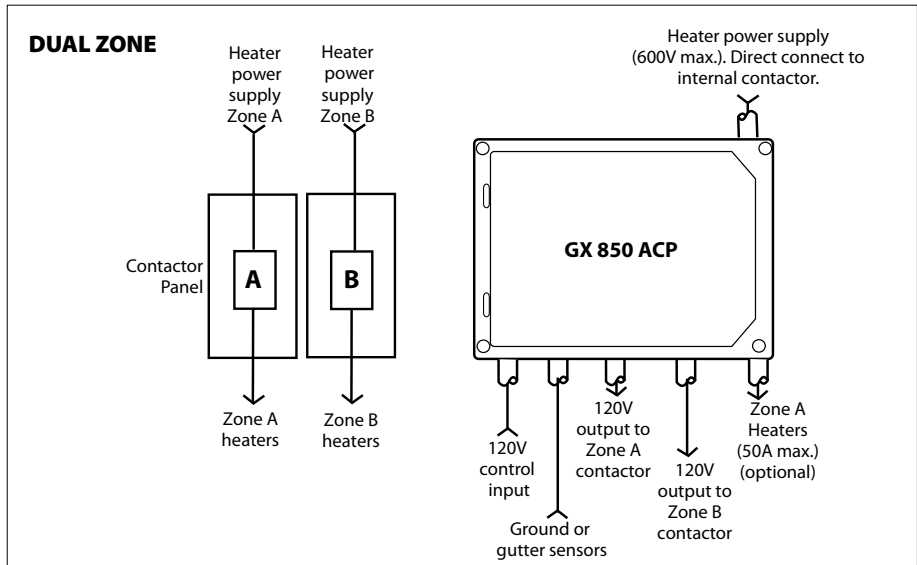
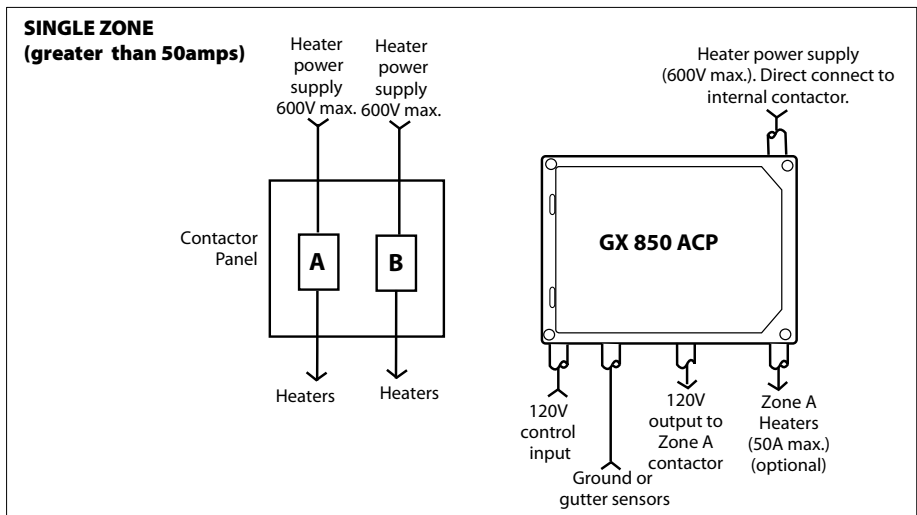
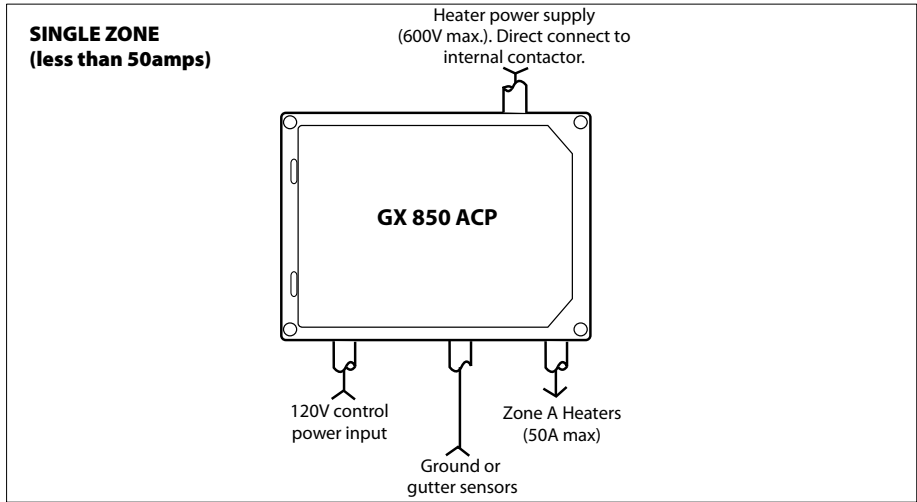

Terminal Block

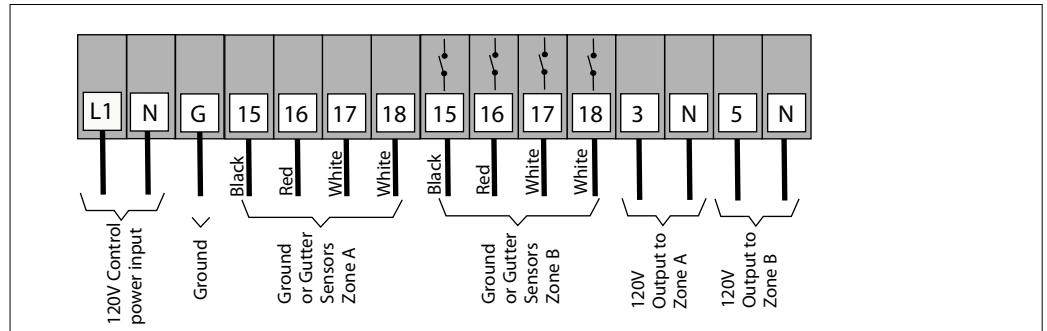

The required power output for your heating system should be determined by a qualified electrician.

CAUTION!

It is important that this equipment is installed only by qualified electricians who are familiar with the proper sizing, installation, construction and operation of outdoor heating systems and the hazards involved. The GX system is designed for outdoor ice and snow melting applications only.

NOTE!

The installation shall be in accordance with the manufacture's instructions and national and local electrical codes. The installation shall be in accordance with part 426, American National Standard Institute / National Fire Protection Association (ANSI/NFPA70), National Electrical Code (NEC) and Canadian Electrical Code (CEC), part 1. You must use a ground fault protection device (GFCI) or a Residual Current Device (RCD) for outdoor areas.

Installing Ground Sensors

Correct placing of the sensor(s) is important for the system to work as intended. Some basic guidelines:

The number of ground sensors:

- 1) The more sensors you add to your system the better the performance.
- 2) The basic principle is to place one sensor where the snow/ice will appear first (for fast detection) and one sensor where the snow/ice will disappear last (for complete melting). If it is not obvious just place the sensors as far apart from each other as possible.
- 3) With only one sensor you will have to decide what is most important:
 - a) fast detection and activation of the system or
 - b) securing a complete melting of all snow/ice. A one sensor ground system will be less fast regarding detection and activation than a two sensor ground system, where one sensor measures the ground temperature and the other sensor measures the moist.
- 4) With more than two sensors it is possible to cover problem spots where snow usually is not detected or where snow is not completely melted when the system stops.

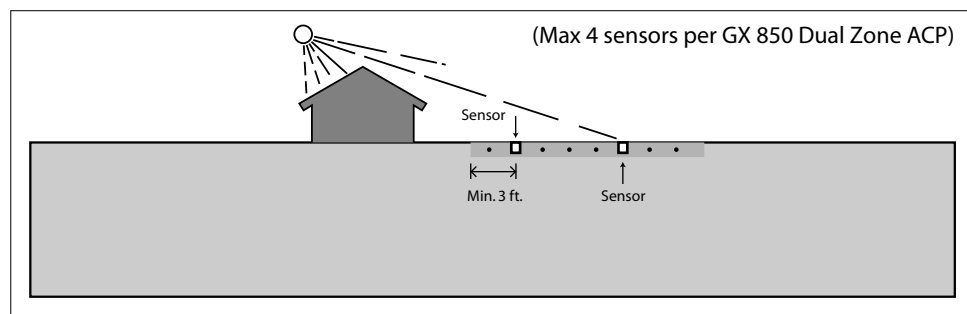

Installing an Individual Ground Sensor

- 1) The sensor must be placed within the heated area and at least 3.3' (1m) from the edge of the area, if possible.
- 2) The sensor must be placed in between the heating cables - a distance of minimum 0.4" (1cm) should be maintained between the sensor tube and the heating cable.
- 3) There must be a distance of minimum 3.3ft. (1m) between the two sensors.

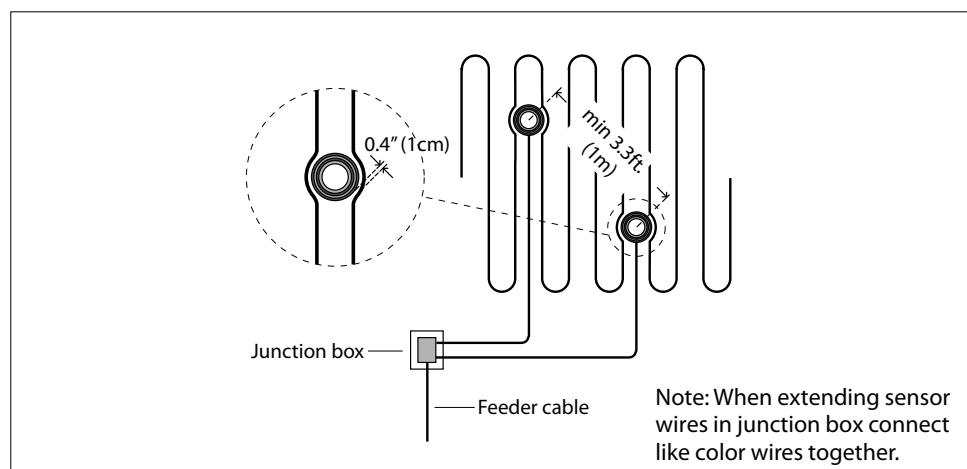

Installing a Sensor Cable

A feeder cable for a sensor may be needed. A 50' (15m) cable is supplied with each sensor. Approx. 1.5' (0.5m) of this cable should be coiled inside the bottom of the sensor tube. The remaining cable may be extended. The feeder cable must be a four wire cable.

Installing a Ground Sensor and a Conduit

The sensor and the conduit may be installed in connection with the actual construction work and connected at a later date. The following applies for all types of installations:

- 1: Ensure that the conduit is sealed when the concrete is poured.
- 2: The conduit must be positioned so that it is flush with the surrounding terrain. The sensor must be placed so that the upper brass surface is horizontal.
- 3: The base below the tube must be hard, e.g. a concrete plate or similar, in order to ensure that the sensor is not pushed into the ground if e.g. a vehicle runs over it. The tube is designed to be mounted on a plate using the two screw holes inside the conduit.
- 4: A metal/plastic pipe, through which the sensor cable may be passed, should be run as far as the sensor conduit.
- 5: Coil approx. 1.5' (0.5m) of the sensor cable inside the conduit.
- 6: Place the sensor inside the tube until it is horizontally flush with the edge of the conduit and "resting" on the internal collar inside the conduit. The sensor may be extracted at a later date using the two holes found around the edge of the sensor conduit. The grooves on the outside of the sensor should correspond with the holes in the conduit.

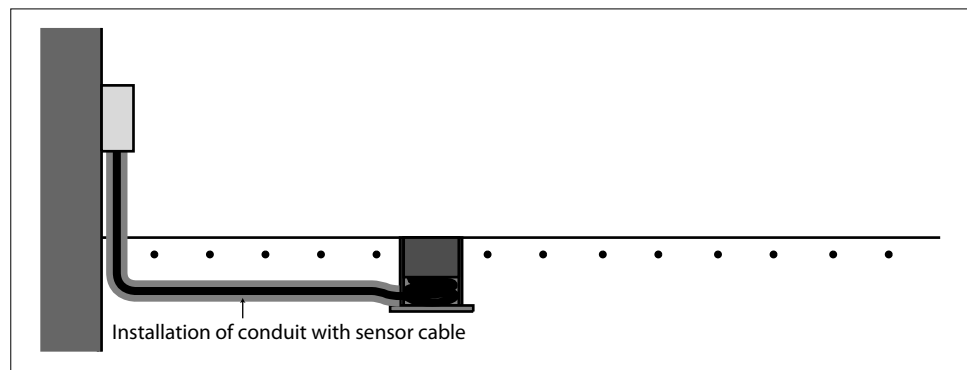

Installation in Asphalt

The temperature **must not exceed 176°F (80°C)** around the sensor/tube. A wooden block or similar may be placed in the area where the tube/sensor can be placed subsequently. The installation pipe used for the sensor cable should, in that case, be a metal tube that can withstand the high temperatures.

Installing Roof Sensors

Correct placing of the sensor(s) is important for the system to work as intended.

The number of roof sensors:

- 1) The more sensors you add to your system the better the performance.
- 2) The basic principle is to place one sensor where the snow/ice will appear first (for fast detection) and one sensor where the snow/ice will disappear last (for complete melting). If it is not obvious just place the sensors as far apart from each other as possible.
- 3) With more than two sensors it is also possible to cover problem spots where snow usually is not detected or where snow is not completely melted when the system stops.

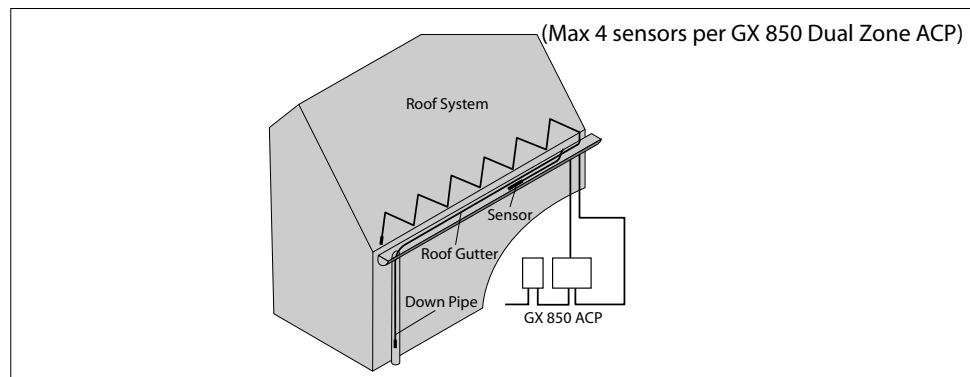

Installing an Individual Roof Sensor

- 1) The sensor should be installed in the heated surroundings most often in the roof gutter, but it could also be installed on the roof in special applications.
- 2) The sensor should be located where the first water and snow is expected to "hit" the roof gutter. Make sure the sensor is placed in an open environment, and is not covered by trees, other buildings, shadows etc., and preferably where ice and snow usually cause the most problems.
- 3) There is no general recommendation for placing a sensor with regards to direction (N, S, E, W). Based on experience the most likely position is in the North or Northwest roof gutter.



Factory Settings



Ground Application

Settings		
Function	Factory settings	Options
Moisture level	50	5 to 95 (5 being the most sensitive to moisture)
Standby temperature	27°F (-3°C)	- 4°F to 32°F (-20°C to 0°C)
Melting temperature	39°F (4°C)	34°F to 50°F (1°C to 10°C)
Post-heat	1 hour	0 to 9 hours
Clogged drain	On	On/off
System mode	Automatic	<ul style="list-style-type: none"> • Automatic • Constant On (manual timer, 9H) • Manually Off

Roof Application

Settings		
Function	Factory settings	Options
Moisture level	50	5 to 95 (5 being the most sensitive to moisture)
Melting temperature	35°F (1.5°C)	32°F to 50°F (0°C to 10°C)
Post-heat	1 hour	0 to 9 hours
Clogged drain	On	On/off
System mode	Automatic	<ul style="list-style-type: none"> • Automatic • Constant On (manual timer) • Manually Off

Part Numbers



GX controls

Part No.	Description	Voltage
088L3411	GX 850 Automatic Control Panel (ACP)	208V-600V
088L3440	GX Contactor Panel with 4hr timer	208V-600V
088L3441	GX Contactor Panel without timer	208V-600V
088L3442	GX Timer Panel with 4 hr timer	208V-600V
088L3443	GX Timer Panel without timer	208V-600V
088L3444	GX Contactor Panel with timer and GFEP, 100A	208V-600V
088L3445	GX Contactor Panel with GFEP, 100A	208V-600V
088L3446	GX Contactor Panel with timer and GFEP, 200A	208V-600V
088L3447	GX Contactor Panel with GFEP, 200A	208V-600V

GX sensors

088L3051	Ground sensors (two per package)
088L3052	Roof sensor

GX accessories

088L3405	Nameplate (per NEC 426-13)
----------	----------------------------

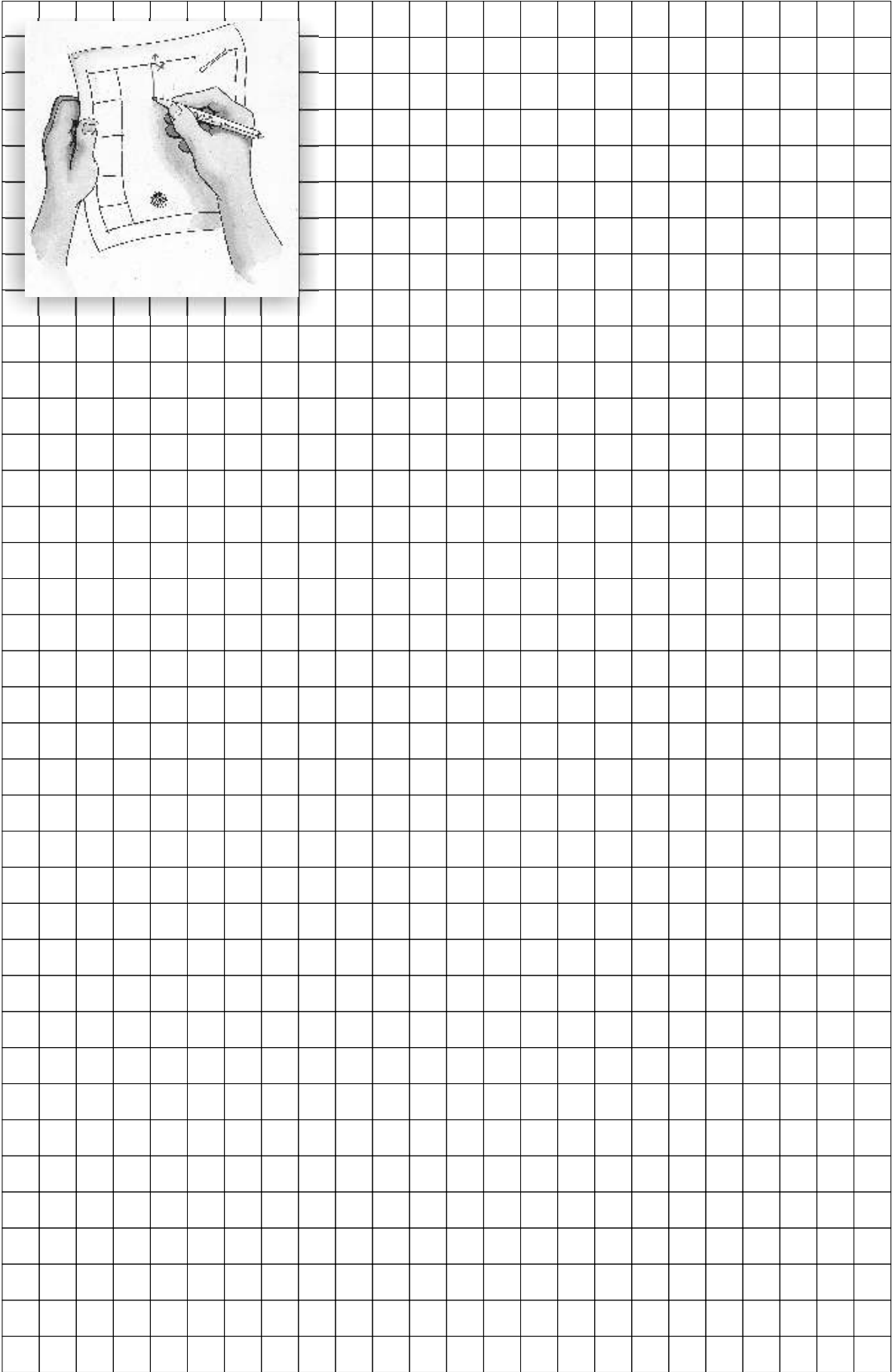
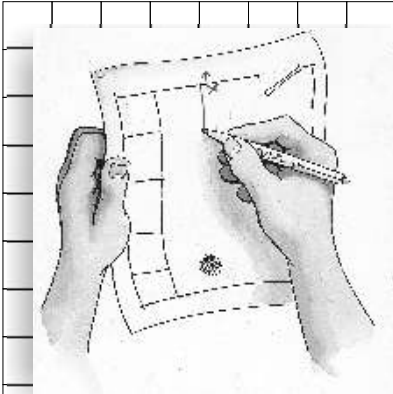



DANFOSS GX 850 DUAL ZONE ACP WARRANTY

For a period of two (2) years from the date of purchase Danfoss warrants that the Danfoss GX 850 Dual Zone Automatic Control Panel (ACP) is free from defects in material, design and workmanship. The warranty is only valid if the warranty certificate is correctly filled out and the installation is in accordance with the installation instructions.

The warranty certificate shall be presented to Danfoss in the case a claim is made. The defective Danfoss GX 850 Dual Zone ACP has to be inspected by or submitted to Danfoss or an authorized Danfoss GX dealer. Failure to comply with the before mentioned conditions will void this warranty.

Danfoss will, when the customer has documented that a defect in the Danfoss GX 850 Dual Zone ACP was present at the date of delivery, repair or supply a new Danfoss GX 850 Dual Zone ACP at Danfoss' option. All claims shall be made within the warranty period. Danfoss shall not be liable for any claims made later than two (2) years from date of purchase. Danfoss shall not be liable for any consequential and secondary costs or damages linked to the defect or replacement of the Danfoss GX 850 Dual Zone ACP.

THE FOREGOING WARRANTY IS EXPRESSLY IN LIEU OF ALL OTHER WARRANTIES, EXPRESS OR IMPLIED, ON THE PART OF DANFOSS. DANFOSS DISCLAIMS ANY WARRANTY, EXPRESS OR IMPLIED, OF MERCHANTABILITY OR FITNESS FOR A PARTICULAR PURPOSE. DANFOSS NEITHER ASSUMES NOR AUTHORIZES ANY OTHER PERSON, FIRM OR CORPORATION TO ASSUME FOR IT ANY OTHER LIABILITY IN CONNECTION WITH SALE OR PRODUCT. DANFOSS SHALL NOT BE HELD RESPONSIBLE FOR DAMAGE TO PERSON OR PROPERTY, CONSEQUENTIAL LOSS, LOSS OF PROFIT, LOSSES ON GOODS IN STORE, OR THE LIKE WHICH MIGHT ARISE OUT OF THE FAILURE OF THE EQUIPMENT DELIVERED, IRRESPECTIVE OF THE CAUSE (INCLUDING FAULTY MANUFACTURE).

How to claim this warranty

Contact the company's Customer Service department and provide the following information:

- 1) Nature of the manufacturing defect
- 2) Date of purchase and, if already installed, date of installation
- 3) If installed, name of electrician and flooring installer
- 4) Resistance readings taken by installer
- 5) Proof of purchase and serial number from product label

Our Customer Service department will provide you with an authorization number and advise you on the next steps to complete your warranty claim.

Disclaimer:

This warranty gives you specific legal rights and you may also have some legal rights which may vary from state to state or province to province. Danfoss hereby disclaims, and it is as a condition of the sale, that there are no implied warranties. Some states and provinces do not allow limitations on an implied warranty so the above limitation may not apply to you.

Manufacturer:

Mail: Danfoss Inc.
6711 Mississauga Rd.,
Suite 410
Toronto, ON
L5N 2W3
Phone: 905-285-2050
1-866-676-8062
Fax: 905-285-2055

Danfoss can accept no responsibility for possible errors in catalogues, brochures, other printed materials, and website information. Danfoss reserves the right to alter its products without notice. This also applies to products already on order provided that such alteration can be made without subsequent changes being necessary in specifications already agreed upon. All trademarks in this material are property of the respective companies. Danfoss and the Danfoss logotype are registered trademarks of Danfoss A/S. All rights reserved.

The Danfoss logo is a stylized, cursive script of the word "Danfoss" in black, with a horizontal line underneath the letters.

Danfoss Inc.
Toronto
Toll Free: 866-676-8062
Phone: 905-285-2050
Fax: 905-285-2055
www.LX.Danfoss.com

Danfoss **GX**
BRINGING WARMTH TO LIFE